

Australian/New Zealand Standard™

**Occupational protective gloves
Part 10.2: Protective gloves against
chemicals and micro-organisms—
Determination of resistance to
penetration**

[CEN title: Protective gloves against chemicals and micro-organisms,
Part 2: Determination of resistance to penetration]

AS/NZS 2161.10.2:2002

This Joint Australian/New Zealand Standard was prepared by Joint Technical Committee SF-023, Occupational Protective Gloves. It was approved on behalf of the Council of Standards Australia on 14 July 2002 and on behalf of the Council of Standards New Zealand on 27 June 2002. It was published on 23 August 2002.

The following are represented on Committee SF-023:

Australasian Fire Authorities Council
Australian Association of Certification Bodies
Australian Chamber of Commerce and Industry
Bureau of Steel Manufacturers of Australia
Griffith University
N.S.W. Rural Fire Service
Telstra Corporation
TestSafe Australia
The University of New South Wales
University of Otago, New Zealand
WorkSafe Western Australia

Keeping Standards up-to-date

Standards are living documents which reflect progress in science, technology and systems. To maintain their currency, all Standards are periodically reviewed, and new editions are published. Between editions, amendments may be issued. Standards may also be withdrawn. It is important that readers assure themselves they are using a current Standard, which should include any amendments which may have been published since the Standard was purchased.

Detailed information about joint Australian/New Zealand Standards can be found by visiting the Standards Australia web site at www.standards.com.au or Standards New Zealand web site at www.standards.co.nz and looking up the relevant Standard in the on-line catalogue.

Alternatively, both organizations publish an annual printed Catalogue with full details of all current Standards. For more frequent listings or notification of revisions, amendments and withdrawals, Standards Australia and Standards New Zealand offer a number of update options. For information about these services, users should contact their respective national Standards organization.

We also welcome suggestions for improvement in our Standards, and especially encourage readers to notify us immediately of any apparent inaccuracies or ambiguities. Please address your comments to the Chief Executive of either Standards Australia International or Standards New Zealand at the address shown on the back cover.

Australian/New Zealand Standard™

**Occupational protective gloves
Part 10.2: Protective gloves against
chemicals and micro-organisms—
Determination of resistance to
penetration**

First published as AS/NZS 2161.10.2:2002.

COPYRIGHT

© Standards Australia/Standards New Zealand

All rights are reserved. No part of this work may be reproduced or copied in any form or by any means, electronic or mechanical, including photocopying, without the written permission of the publisher.

Jointly published by Standards Australia International Ltd, GPO Box 5420, Sydney, NSW 2001 and Standards New Zealand, Private Bag 2439, Wellington 6020

ISBN 0 7337 4729 9

PREFACE

This Standard was prepared by the Joint Standards Australia/Standards New Zealand Committee SF-023, Occupational Protective Gloves.

This Standard is identical with and has been reproduced from the European (CEN) Standard EN 374-2:1994, *Protective gloves against chemicals and micro-organisms, Part 2: Determination of resistance to penetration*.

As this Standard is reproduced from a European Standard, the following applies:

- (a) Its number appears on the cover and title page while the European Standard number appears only on the cover.
- (b) In the source text, 'this European Standard' should read 'this Australian/New Zealand Standard'.
- (c) A full point substitutes for a comma when referring to a decimal marker.

The objective of Part 10.2 of AS/NZS 2161 is to provide uses and manufacturers with a method for testing gloves against leakage of air or water, so that such gloves can provide a barrier to biologically hazardous material.

CONTENTS

	<i>Page</i>
1 Scope.....	1
2 Principle of test.....	1
3 Sampling.....	1
4 Apparatus	1
5 Procedure.....	2
6 Test report	4

NOTES

AUSTRALIAN/NEW ZEALAND STANDARD

Occupational protective gloves

Part 10.2:

Protective gloves against chemicals and micro-organisms—Determination of resistance to penetration

1 Scope

This standard specifies a test method for the penetration resistance of gloves that protect against chemicals and/or micro-organisms.

At this time it is believed that gloves which resist penetration, when tested according to this Part of EN 374, will form an effective barrier to micro-biological hazards.

2 Principle of test

The primary test is an air leak test.

A glove is immersed in water, and its interior is pressurized with air. The leak is detected by a stream of air bubbles from the surface of the glove.

This air leak procedure is not suitable for all gloves. For example parts of some gloves may be over-inflated while other parts of the same gloves may only be partially inflated or not even filled at all with air. If the air leak test proves unsuitable, then a secondary test is carried out by filling a glove with water. A leak is detected by the appearance of water droplets on the outside of the glove.

For both methods disregard leaks within the area of 40 mm from the edge of cuff.

3 Sampling

The test sample will be one glove irrespective of how the gloves are packaged, labelled, and offered for sale and use.

4 Apparatus

4.1 Air leak test

4.1.1 A circular fixing mandrel, tapered with an appropriate diameter range to effect an airtight seal with the glove to be tested. It should be capable of rotation through 360°.

4.1.2 Means of air inflation.

4.1.3 Water tank.

4.1.4 Pressure gauge reading 0 kPa to 10 kPa.

4.1.5 Means of regulating the desired pressure.

Figure 1 and Figure 2 show an example of a suitable apparatus.

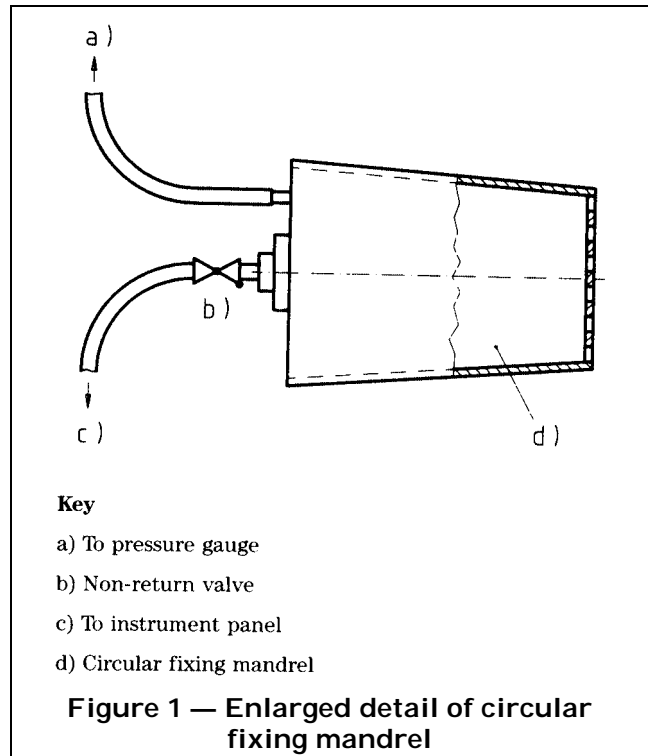

4.2 Water leak test

4.2.1 A clear open ended tube is fitted with a hook at the upper end. The tube measures 380 mm in length and has a diameter wide enough to fit the gloves under test. It has a mark 40 mm from the lower end (see Figure 3).

4.2.2 Elastic strapping with a “touch and close” fastener or other fastening material.

4.2.3 Stand with horizontal rod for hanging the hook end of the plastic tube (see Figure 4). The supported rod shall be capable of taking the weight of the total number of gloves, that will be suspended at any one time.

4.2.4 An automatic water dispenser or manual device capable of delivering a minimum of 1 000 ml water.

4.2.5 An alternative means of holding the glove may be used. The apparatus shall be capable of securing the glove on a mandrel, with a diameter appropriate to fit the glove, so that it can be filled with water to within 40 mm from the edge of cuff. It shall be capable of holding water in excess of that required to fill the glove.