



BSI Standards Publication

# Performance of high-voltage direct current (HVDC) systems with line-commutated converters

---

Part 1: Steady-state conditions

## National foreword

This Published Document is the UK implementation of IEC TR 60919-1:2020. It supersedes PD IEC/TR 60919-1:2010+A2:2017, which is withdrawn.

The UK participation in its preparation was entrusted to Technical Committee PEL/22, Power electronics.

A list of organizations represented on this committee can be obtained on request to its secretary.

This publication does not purport to include all the necessary provisions of a contract. Users are responsible for its correct application.

© The British Standards Institution 2020  
Published by BSI Standards Limited 2020

ISBN 978 0 580 52426 4

ICS 29.200; 29.240.99

**Compliance with a British Standard cannot confer immunity from legal obligations.**

This Published Document was published under the authority of the Standards Policy and Strategy Committee on 30 April 2020.

### Amendments/corrigenda issued since publication

Date	Text affected
------	---------------

---



# TECHNICAL REPORT



---

**Performance of high-voltage direct current (HVDC) systems with  
line-commutated converters –  
Part 1: Steady-state conditions**

INTERNATIONAL  
ELECTROTECHNICAL  
COMMISSION

---

ICS 29.200; 29.240.99

ISBN 978-2-8322-8038-6

**Warning! Make sure that you obtained this publication from an authorized distributor.**

## CONTENTS

FOREWORD .....	8
INTRODUCTION .....	10
1 Scope .....	11
2 Normative references .....	12
3 Terms and definitions .....	12
4 Types of HVDC systems .....	12
4.1 General .....	12
4.2 HVDC back-to-back system .....	12
4.3 Monopolar HVDC system with earth return .....	13
4.4 Monopolar HVDC system with metallic return .....	16
4.5 Bipolar earth return HVDC system .....	17
4.6 Bipolar HVDC system with metallic return .....	20
4.7 Two 12-pulse groups per pole .....	21
4.8 Converter transformer arrangements .....	24
4.9 DC switching considerations .....	25
4.10 Series-capacitor-compensated HVDC systems .....	28
4.11 LCC/VSC hybrid bipolar system .....	32
5 Environment information .....	33
6 Rated power, current and voltage .....	36
6.1 Rated power .....	36
6.1.1 General .....	36
6.1.2 Rated power of an HVDC system with transmission line .....	36
6.1.3 Rated power of an HVDC back-to-back system .....	36
6.1.4 Direction of power flow .....	37
6.2 Rated current .....	37
6.3 Rated voltage .....	37
7 Overload and equipment capability .....	37
7.1 Overload .....	37
7.2 Equipment capability .....	38
7.2.1 General .....	38
7.2.2 Converter valve capability .....	38
7.2.3 Capability of oil-cooled transformers and reactors .....	39
7.2.4 AC harmonic filter and reactive power compensation equipment capability .....	39
7.2.5 Switchgear and buswork capability .....	39
8 Minimum power transfer and no-load stand-by state .....	39
8.1 General .....	39
8.2 Minimum current .....	39
8.3 Reduced direct voltage operation .....	40
8.4 No-load stand-by state .....	40
8.4.1 General .....	40
8.4.2 Converter transformers – No-load stand-by .....	40
8.4.3 Converter valves – No-load stand-by .....	40
8.4.4 AC filters and reactive compensation – No-load stand-by .....	41
8.4.5 DC reactors and DC filters – No-load stand-by .....	41

8.4.6	Auxiliary power system – No-load stand-by.....	41
8.4.7	Control and protection – No-load stand-by.....	41
9	AC system.....	41
9.1	General.....	41
9.2	AC voltage.....	41
9.2.1	Rated AC voltage.....	41
9.2.2	Steady-state voltage range.....	41
9.2.3	Negative sequence voltage.....	42
9.3	Frequency.....	42
9.3.1	Rated frequency.....	42
9.3.2	Steady-state frequency range.....	43
9.3.3	Short-term frequency variation.....	43
9.3.4	Frequency variation during emergency.....	43
9.4	System impedance at fundamental frequency.....	43
9.5	System impedance at harmonic frequencies.....	43
9.6	Positive and zero-sequence surge impedance.....	43
9.7	Other sources of harmonics.....	44
9.8	Subsynchronous torsional interaction (SSTI).....	44
10	Reactive power.....	44
10.1	General.....	44
10.2	Conventional HVDC systems.....	44
10.3	Series capacitor compensated HVDC schemes.....	46
10.4	Converter reactive power consumption.....	46
10.5	Reactive power balance with the AC system.....	46
10.6	Reactive power supply.....	46
10.7	Maximum size of switchable VAR banks.....	47
11	HVDC transmission line, earth electrode line and earth electrode.....	47
11.1	General.....	47
11.2	Overhead line(s).....	47
11.2.1	General.....	47
11.2.2	Electrical parameters.....	47
11.3	Cable line(s).....	48
11.3.1	General.....	48
11.3.2	Electrical parameters.....	48
11.4	Earth electrode line.....	49
11.5	Earth electrode.....	49
12	Reliability.....	49
12.1	General.....	49
12.2	Outage.....	49
12.2.1	General.....	49
12.2.2	Scheduled outage.....	49
12.2.3	Forced outage.....	49
12.3	Capacity.....	50
12.3.1	General.....	50
12.3.2	Maximum continuous capacity $P_m$ .....	50
12.3.3	Outage capacity $P_o$ .....	50
12.3.4	Outage derating factor (ODF).....	50
12.4	Outage duration terms.....	50

12.4.1	Actual outage duration (AOD) .....	50
12.4.2	Equivalent outage duration (EOD) .....	50
12.4.3	Period hours (PH) .....	50
12.4.4	Actual outage hours (AOH) .....	51
12.4.5	Equivalent outage hours (EOH) .....	51
12.5	Energy unavailability (EU) .....	51
12.5.1	General .....	51
12.5.2	Forced energy unavailability (FEU) .....	51
12.5.3	Scheduled energy unavailability (SEU) .....	52
12.6	Energy availability (EA) .....	52
12.7	Maximum permitted number of forced outages .....	52
12.8	Statistical probability of outages .....	52
12.8.1	Component faults .....	52
12.8.2	External faults .....	52
13	HVDC control .....	52
13.1	Control objectives .....	52
13.2	Control structure .....	53
13.2.1	General .....	53
13.2.2	Converter unit firing control .....	53
13.2.3	Pole control .....	54
13.2.4	HVDC substation control .....	56
13.2.5	Master control .....	58
13.3	Control order settings .....	58
13.4	Current limits .....	58
13.5	Control circuit redundancy .....	59
13.6	Protection system .....	59
13.7	Measurements .....	59
14	Telecommunication .....	60
14.1	Types of telecommunication links .....	60
14.2	Telephone .....	60
14.3	Power line carrier (PLC) .....	60
14.4	Microwave .....	61
14.5	Radio link .....	61
14.6	Optical fibre telecommunication .....	61
14.7	Classification of data to be transmitted .....	61
14.8	Fast response telecommunication .....	62
14.9	Reliability .....	62
15	Auxiliary power supplies .....	63
15.1	General .....	63
15.2	Reliability and load classification .....	63
15.3	AC auxiliary supplies .....	64
15.4	Batteries and uninterruptible power supplies (UPS) .....	64
15.5	Emergency supply .....	65
16	Audible noise .....	65
16.1	General .....	65
16.2	Public nuisance .....	65
16.2.1	General .....	65
16.2.2	Valves and valve coolers .....	66

16.2.3	Converter transformers .....	66
16.2.4	DC reactors .....	66
16.2.5	AC filter reactors .....	66
16.3	Noise in working areas .....	66
17	Harmonic interference – AC .....	67
17.1	AC side harmonic generation .....	67
17.2	Filters .....	67
17.3	Interference disturbance criteria .....	70
17.4	Levels for interference .....	71
17.5	Filter performance .....	72
18	Harmonic interference – DC .....	72
18.1	DC side interference .....	72
18.1.1	Harmonic currents in HVDC transmission line .....	72
18.1.2	Characteristic and non-characteristic harmonics .....	72
18.1.3	Groups of harmonics .....	73
18.1.4	Calculation of harmonic currents .....	73
18.1.5	Calculation of induced voltages .....	73
18.1.6	Personnel safety .....	73
18.1.7	DC filters .....	73
18.2	DC filter performance .....	74
18.2.1	Requirements for voice communication circuits .....	74
18.2.2	Levels of interference .....	74
18.2.3	Safety .....	74
18.3	Specification requirements .....	75
18.3.1	Economic level of filtering .....	75
18.3.2	General criteria .....	76
18.3.3	Factors to be taken into account for calculations .....	76
18.3.4	Calculation of currents .....	77
19	Power line carrier interference (PLC) .....	77
19.1	General .....	77
19.2	Performance specification .....	78
20	Radio frequency interference .....	79
20.1	General .....	79
20.2	RFI from HVDC systems .....	80
20.2.1	RFI sources .....	80
20.2.2	RFI propagation .....	80
20.2.3	RFI characteristics .....	80
20.3	RFI performance specification .....	81
20.3.1	RFI risk assessment .....	81
20.3.2	Specification RFI limit and its verification .....	81
20.3.3	Design aspects .....	82
21	Power losses .....	82
21.1	General .....	82
21.2	Main contributing sources .....	83
21.2.1	General .....	83
21.2.2	AC filters and reactive power compensation .....	83
21.2.3	Converter bridges .....	83
21.2.4	Converter transformer .....	83

21.2.5	DC reactor .....	83
21.2.6	DC filter .....	84
21.2.7	Auxiliary equipment .....	84
21.2.8	Other components .....	84
22	Provision for extensions to the HVDC systems .....	84
22.1	General.....	84
22.2	Specification for extensions .....	84
Annex A	(informative) Factors affecting reliability and availability of converter stations .....	87
A.1	Design and documentation.....	87
A.1.1	General .....	87
A.1.2	General design principles .....	87
A.1.3	More detailed design principles .....	88
A.1.4	Software design principles .....	88
A.1.5	RAM records.....	89
A.2	Operation.....	89
A.2.1	Training .....	89
A.2.2	Maintenance programs affecting reliability .....	90
A.2.3	Spare parts.....	91
Bibliography	.....	94
Figure 1	– Twelve-pulse converter unit .....	11
Figure 2	– Examples of back-to-back HVDC systems .....	13
Figure 3	– Monopolar HVDC system with earth return .....	14
Figure 4	– Two 12-pulse units in series.....	15
Figure 5	– Two 12-pulse units in parallel.....	16
Figure 6	– Monopolar HVDC system with metallic return .....	17
Figure 7	– Bipolar system .....	18
Figure 8	– Metallic return operation of the unfaulted pole in a bipolar system.....	19
Figure 9	– Bipolar HVDC system with metallic return .....	21
Figure 10	– Bipolar system with two 12-pulse units in series per pole .....	23
Figure 11	– Bipolar system with two 12-pulse units in parallel per pole .....	24
Figure 12	– DC switching of line conductors .....	26
Figure 13	– DC switching of converter poles .....	27
Figure 14	– DC switching – Overhead line to cable .....	28
Figure 15	– DC switching – Two bipolar converters and lines .....	29
Figure 16	– DC switching – Intermediate.....	30
Figure 17	– Capacitor commutated converter configurations .....	31
Figure 18	– LCC/VSC hybrid bipolar system .....	33
Figure 19	– Variations of reactive power $Q$ with active power $P$ of an HVDC converter .....	45
Figure 20	– Control hierarchy for HVDC/UHVDC system.....	55
Figure 21	– Converter voltage-current characteristic .....	57
Figure 22	– Examples of AC filter connections for a bipole HVDC system .....	68
Figure 23	– Circuit diagrams for different filter types .....	69
Figure 24	– RY COM interference meter results averaged – Typical plot of converter interference levels on the DC line .....	79

Figure 25 – Recommended measurement procedure with definition of measuring point .....	82
Figure 26 – Extension methods for HVDC systems .....	86
Table 1 – Information supplied for HVDC substation .....	34
Table 2 – Performance parameters for voice communication circuits: Subscribers and trunk circuits .....	75

## INTERNATIONAL ELECTROTECHNICAL COMMISSION

**PERFORMANCE OF HIGH-VOLTAGE DIRECT CURRENT  
(HVDC) SYSTEMS WITH LINE-COMMUTATED CONVERTERS –****Part 1: Steady-state conditions**

## FOREWORD

- 1) The International Electrotechnical Commission (IEC) is a worldwide organization for standardization comprising all national electrotechnical committees (IEC National Committees). The object of IEC is to promote international co-operation on all questions concerning standardization in the electrical and electronic fields. To this end and in addition to other activities, IEC publishes International Standards, Technical Specifications, Technical Reports, Publicly Available Specifications (PAS) and Guides (hereafter referred to as "IEC Publication(s)"). Their preparation is entrusted to technical committees; any IEC National Committee interested in the subject dealt with may participate in this preparatory work. International, governmental and non-governmental organizations liaising with the IEC also participate in this preparation. IEC collaborates closely with the International Organization for Standardization (ISO) in accordance with conditions determined by agreement between the two organizations.
- 2) The formal decisions or agreements of IEC on technical matters express, as nearly as possible, an international consensus of opinion on the relevant subjects since each technical committee has representation from all interested IEC National Committees.
- 3) IEC Publications have the form of recommendations for international use and are accepted by IEC National Committees in that sense. While all reasonable efforts are made to ensure that the technical content of IEC Publications is accurate, IEC cannot be held responsible for the way in which they are used or for any misinterpretation by any end user.
- 4) In order to promote international uniformity, IEC National Committees undertake to apply IEC Publications transparently to the maximum extent possible in their national and regional publications. Any divergence between any IEC Publication and the corresponding national or regional publication shall be clearly indicated in the latter.
- 5) IEC itself does not provide any attestation of conformity. Independent certification bodies provide conformity assessment services and, in some areas, access to IEC marks of conformity. IEC is not responsible for any services carried out by independent certification bodies.
- 6) All users should ensure that they have the latest edition of this publication.
- 7) No liability shall attach to IEC or its directors, employees, servants or agents including individual experts and members of its technical committees and IEC National Committees for any personal injury, property damage or other damage of any nature whatsoever, whether direct or indirect, or for costs (including legal fees) and expenses arising out of the publication, use of, or reliance upon, this IEC Publication or any other IEC Publications.
- 8) Attention is drawn to the Normative references cited in this publication. Use of the referenced publications is indispensable for the correct application of this publication.
- 9) Attention is drawn to the possibility that some of the elements of this IEC Publication may be the subject of patent rights. IEC shall not be held responsible for identifying any or all such patent rights.

The main task of IEC technical committees is to prepare International Standards. However, a technical committee may propose the publication of a technical report when it has collected data of a different kind from that which is normally published as an International Standard, for example "state of the art".

IEC TR 60919-1, which is a technical report, has been prepared by subcommittee 22F: Power electronics for electrical transmission and distribution systems, of IEC technical committee 22: Power electronic systems and equipment.

This fourth edition cancels and replaces the third edition, published in 2010, Amendment 1:2013 and Amendment 2:2017. This edition constitutes a technical revision.

This edition includes the following significant technical changes with respect to the previous edition:

- a) Figure 8 and Figure 20 have been updated, a new Figure 18 "LCC/VSC hybrid bipolar system" has been added;
- b) the HVDC system control objectives have been supplemented;
- c) additional explanations regarding the HVDC system control structure have been given;
- d) a new subclause 13.6 on HVDC system protection has been added.

The text of this Technical Report is based on the following documents:

Draft TR	Report on voting
22F/535/DTR	22F/549A/RVDTR

Full information on the voting for the approval of this Technical Report can be found in the report on voting indicated in the above table.

This document has been drafted in accordance with the ISO/IEC Directives, Part 2.

A list of all parts of the IEC 60919 series, published under the general title *Performance of high-voltage direct current (HVDC) systems with line-commutated converters*, can be found on the IEC website.

The committee has decided that the contents of this document will remain unchanged until the stability date indicated on the IEC website under "<http://webstore.iec.ch>" in the data related to the specific document. At this date, the document will be

- reconfirmed,
- withdrawn,
- replaced by a revised edition, or
- amended.

**IMPORTANT – The 'colour inside' logo on the cover page of this publication indicates that it contains colours which are considered to be useful for the correct understanding of its contents. Users should therefore print this document using a colour printer.**

## INTRODUCTION

The difference between system performance specifications and equipment design specifications for individual components of a system is realized. Frequently, performance specifications are prepared as a single package for the two HVDC substations in a particular system. Alternatively, some parts of the HVDC system can be separately specified and purchased. In such cases, due consideration is given to coordination of each part with the overall HVDC system performance objectives and to ensuring that the interface of each with the system is clearly defined. Typical of such parts, listed in the appropriate order of relative ease for separate treatment and interface definition, are:

- a) DC line, electrode line and earth electrode;
- b) telecommunication system;
- c) converter building, foundations and other civil engineering work;
- d) reactive power supply including AC shunt capacitor banks, shunt reactors, synchronous and static reactive power (var) compensators;
- e) AC switchgear;
- f) DC switchgear;
- g) auxiliary systems;
- h) AC filters;
- i) DC filters;
- j) DC reactors;
- k) converter transformers;
- l) surge arresters;
- m) series commutation capacitors;
- n) valves and their ancillaries;
- o) control and protection systems.

NOTE The last four items are the most difficult to separate, and, in fact, separation of these four can be inadvisable.

Clause 4 to Clause 22 of this document set out a complete steady-state performance specification for an HVDC system.

Since the equipment items are usually separately specified and purchased, the HVDC transmission line, earth electrode line and earth electrode (see Clause 11) are included only because of their influence on the HVDC system performance.

For the purpose of this document, an HVDC substation is assumed to consist of one or more converter units installed in a single location together with buildings, reactors, filters, reactive power supply, control, monitoring, protective, measuring and auxiliary equipment. While there is no discussion of AC switching substations in this document, AC filters and reactive power sources are included, although they can be connected to an AC bus separate from the HVDC substation, as discussed in Clause 17.

# PERFORMANCE OF HIGH-VOLTAGE DIRECT CURRENT (HVDC) SYSTEMS WITH LINE-COMMUTATED CONVERTERS –

## Part 1: Steady-state conditions

### 1 Scope

This part of IEC 60919 provides general guidance on the steady-state performance requirements of high-voltage direct current (HVDC) systems. It concerns the steady-state performance of two-terminal HVDC systems utilizing 12-pulse converter units comprised of three-phase bridge (double-way) connections (see Figure 1), but it does not cover multi-terminal HVDC transmission systems. Both terminals are assumed to use thyristor valves as the main semiconductor valves and to have power flow capability in both directions. Diode valves are not considered in this document.

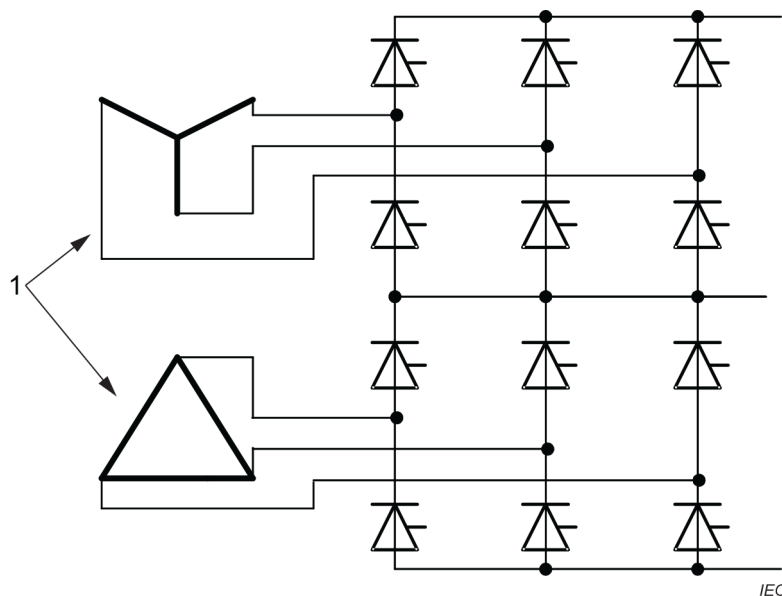

#### Key

1 Transformer valve windings

**Figure 1 – Twelve-pulse converter unit**

Only line-commutated converters are covered in this document, which includes capacitor commutated converter circuit configurations. General aspects of semiconductor line-commutated converters are given in IEC 60146-1-1, IEC TR 60146-1-2 and IEC 60146-1-3. Voltage-sourced converters are not considered.

The distinction is made between system performance specifications and equipment design specifications for individual components of a system. Equipment specifications and testing requirements are not defined in this document. Also excluded from this document are detailed seismic performance requirements. In addition, because there are many variations between different possible HVDC systems, this document does not consider these in detail; consequently, it is not used directly as a specification for a particular project, but rather to provide the basis for an appropriate specification tailored to fit actual system requirements.

This document, which covers steady-state performance, is followed by the additional documents of IEC TR 60919-2 on faults and switching as well as IEC TR 60919-3 on dynamic